



Part No.: L-1045GD



ATTENTION

OBSERVE PRECAUTIONS
FOR HANDLING
ELECTROSTATIC
DISCHARGE
SENSITIVE
DEVICES

➤ **Features**

- Single color
- High bright output
- Low power consumption
- High reliability and long life

➤ **Descriptions:**

- Dice material: InGaN
- Emitting Color:
Pure Green
- Device Outline:
φ 10mm Round Type
- Lens Type:
Green diffused

➤ **Directivity:**

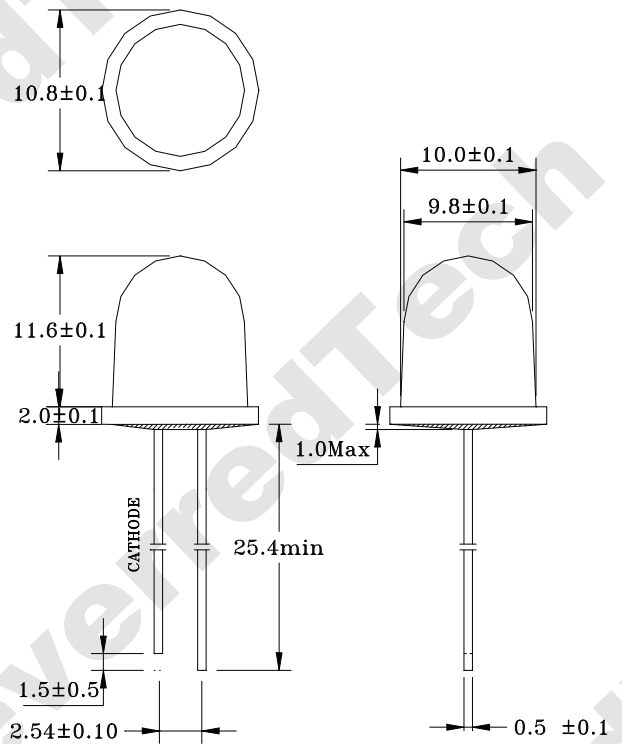

1. All dimensions are millimeters
2. Tolerance is +/-0.25mm unless otherwise noted

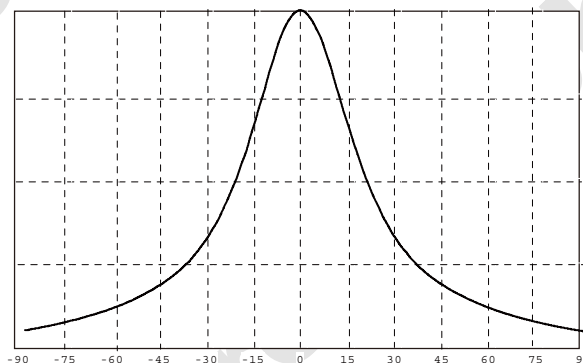



Part No.: L-1045GD

Absolute maximum ratings (Ta = 25°C)

Parameter	Symbol	Test Condition	Value		Unit
			Min.	Max.	
Reverse Voltage	V _R	I _R = 30 μA	5	--	V
Forward Current	I _F	----	----	30	mA
Power Dissipation	P _d	----	----	105	mW
Pulse Current	I _{peak}	Duty=0.1mS, 1kHz	----	100	mA
Operating Temperature	T _{opr}	----	-20	+85	°C
Storage Temperature	T _{str}	----	-25	+100	°C

Electrical and optical characteristics (Ta = 25°C)

Parameter	Symbol	Test Condition	Value			Unit
			Min.	Typ.	Max.	
Forward Voltage	V _F	I _F = 20mA		3.4		
Reverse Current	I _R	V _R = 5V	----	----	30	μA
Dominant Wavelength	λ _d	I _F = 20mA		525		
Spectral Line half-width	Δλ	I _F = 20mA	----	35	----	nm
Luminous Intensity	I _V	I _F = 20mA		1000		
Viewing Angle	2θ 1/2	I _F = 20mA	40		55	Deg.



Part No.: L-1045GD

Typical electrical/optical characteristic curves:

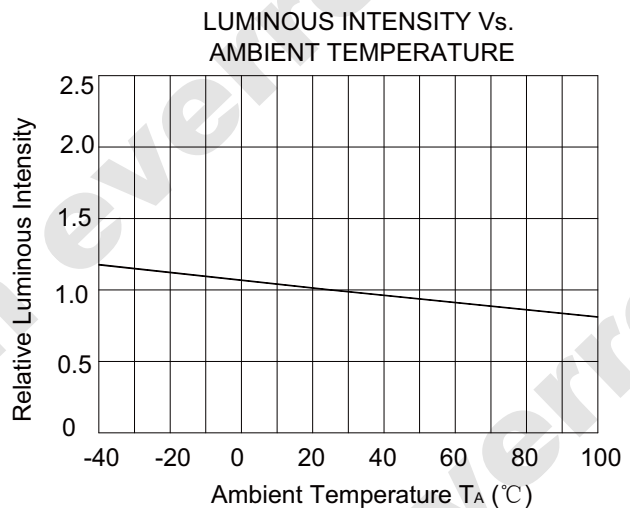
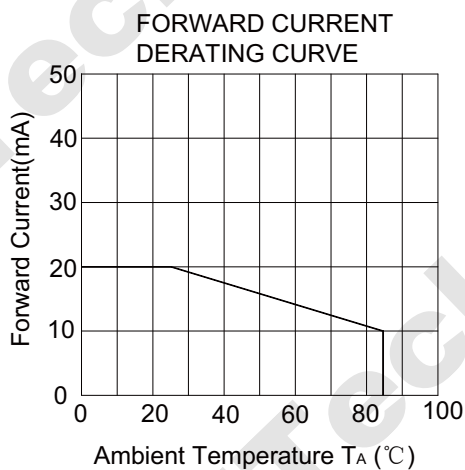
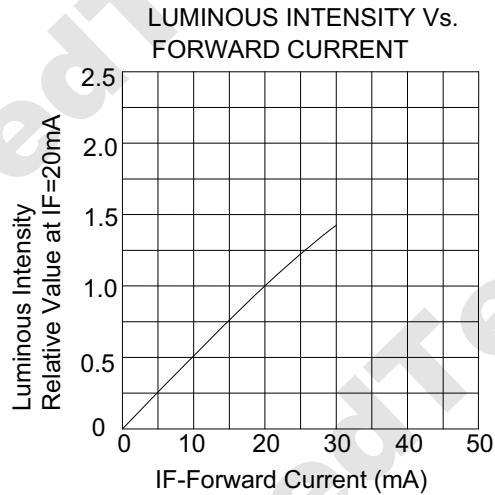
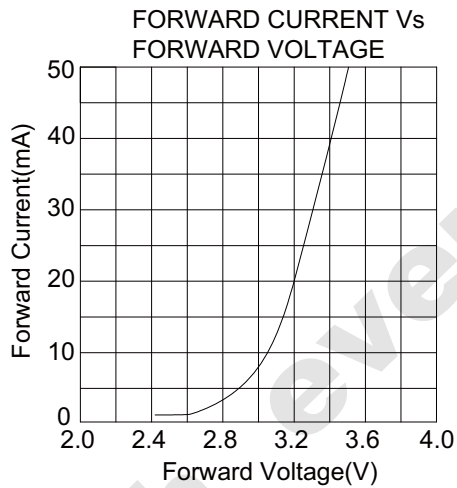

525/35

